

# HOME & PUBLIC ACCESSIBILITY

Product catalogue 2021

- Aritco 4000
- Aritco Access Lift



  
ARITCO™



**Aritco Access Lift is designed to make your home as well as public and commercial buildings accessible for everyone. Practical and smart with sizes for all needs. The lift expresses Scandinavian design and features a backlit panel and lit handlebar. With an option to personalize it with details such as glass walls, a range of various colors and different materials.**

Our journey started 25 years ago, with the simple idea of improving mobility everywhere. Today, Aritco lifts can be found in over 35,000 buildings and private homes around the world.

Simplicity, quality and innovation are the hallmarks of all Aritco's activities. We are constantly seeking new ways to improve the quality, design and user-friendliness of our

products, as well as our environmental impact. Safety and reliability are top priorities, and we follow Europe's strictest quality and safety standards.

All Aritco lifts are developed and produced in Stockholm, Sweden, and we are proud to maintain the highest level of quality in all stages of the process, from design through to final installation.



**ARITCO™**



## Contents

|                                |       |
|--------------------------------|-------|
| Product .....                  | 1-2   |
| Carrier.....                   | 3-4   |
| Control panel.....             | 5-6   |
| Door.....                      | 7     |
| Handle & Floor.....            | 8     |
| Options .....                  | 9-11  |
| Lift wall .....                | 12    |
| Shaf.....                      | 13    |
| FAQ .....                      | 14    |
| Outdoor version .....          | 15    |
| Dimension platform .....       | 16-18 |
| Refernce pictures outdoor..... | 19    |
| Refernce pictures indoor.....  | 20    |
| Smartsafety.....               | 21-22 |

# ARITCO 4000

## THE WORLD'S SMALLEST HOME LIFT

Aritco 4000 is the smallest and most compact home lift in our product range and on the market. The lift has been designed to meet all requirements for comfort, space and design. The lift is available in several different sizes, with an option to personalize it with details such as glass walls, a range of varied colours and different materials.



|                            |   |
|----------------------------|---|
| Technical compliance:      | European Machine directive 2006/42/EC<br>European standard EN 81-41 |
| Drive system:              | Patented screw/nut system   |
| Rated speed (max):         | 0.15 m/s  |
| Travel height:             | 250 - 13,000 mm   |
| Number of stops:           | Max. 6 stops per lift   |
| Number of doors:           | Max. 6 doors per lift   |
| Number of doors per floor: | Max. 2 doors per floor  |
| Pit:                       | 50 mm (no pit is required when there is a threshold/ramp)           |
| Top height:                | Always 2,300 mm   |
| Platform control:          | Auto run  |
| Landing control (on door): | One-touch call  |
| Emergency lowering:        | Battery operated emergency lowering                                 |
| Control voltage:           | 24V   |
| Motor:                     | 1.5kW   |
| Power supply:              | 1-phase 230V 50Hz/6.6A/16A slow                                     |
| Rated load:                | 250 kg  |

### PLATFORM

Aritco 4000 is available in 3 different platform sizes. The rated load is 250 kg and the power supply needed is 230 V 1-phase.

| Platformsize B -side x<br>A/C-side (mm) | Max load<br>(kg) | Power supply  |
|---|------------------|---------------|
| 805 x 580                               | 250              | 230 V 1-phase |
| 805 x 880                               | 250              | 230 V 1-phase |
| 805 x 1080                              | 250              | 230 V 1-phase |

# ARITCO ACCESS LIFT

## THE MOST VERSATILE LIFT

Aritco Access lift is designed to make your home as well as public and commercial buildings accessible for everyone. Practical and smart with sizes for all needs. The lift expresses Scandinavian design and features a backlit panel and lit handlebar. With an option to personalize it with details such as glass walls, a range of various colors and different materials.



|                            |   |
|----------------------------|---|
| Technical compliance:      | European Machine directive 2006/42/EC<br>European standard EN 81-41   |
| Lift type:                 | Platform lift   |
| Drive system:              | Patented screw/nut system   |
| Rated speed (max):         | 0.15 m/s • 0.25 m/s   |
| Travel height:             | 250 - 1,300 <sup>1)</sup> mm<br><small><sup>1)</sup> Travel height when having a half door is maximum 3000 mm (inside EU)</small> |
| Number of stops:           | Max. 6 stops per lift   |
| Number of doors:           | Max. 6 doors per lift   |
| Number of doors per floor: | Max. 2 doors per floor  |
| Pit:                       | 50 mm<br>(no pit is required when there is a ramp)  |
| Entry:                     | One, two or three sides   |
| Top height:                | Minimum 2,240 mm<br>(1,100 - 1,600 mm with half height door)  |
| Platform control:          | Auto run  |
| Landing control (on door): | One-touch call  |
| Emergency lowering:        | Battery operated emergency lowering<br>(manual lowering with a winch as option)   |
| Control voltage:           | 24V   |
| Motor:                     | 2.2 kW  |
| Power supply:              | 1-phase 230V 50 Hz/9 A/16 A slow<br>3-phase 400V 50 Hz/5.2 A/16 A slow  |
| Rated load:                | 250, 410 or 500 kg (depending on platform size)   |

## PLATFORM

Aritco Access lift is available in 8 different platform sizes.

The rated load depends on the platform size.

| Load limits per power supply | 400V 3-phase 50Hz | 400V 3-phase 60Hz | 230V 3-phase 50Hz | 230V 3-phase 60Hz | 230V 1-phase 50/60 Hz |
|------------------------------|-------------------|-------------------|-------------------|-------------------|-----------------------|
| 250 kg                       | ✓                 | ✓                 | ✓                 | ✓                 | ✓                     |
| 410 kg                       | ✓                 | ✓                 | ✓                 | ✓                 | ✓                     |
| 500 kg                       | ✓                 | -                 | ✓                 | -                 | -                     |

| Platform floor area A/C x B (mm) | Max load (kg) |
|----------------------------------|---------------|
| 900 x 1040                       | 250           |
| 900 x 1280                       | 410           |
| 900 x 1480                       | 410, 500      |
| 1000 x 1280                      | 410           |
| 1000 x 1480                      | 410, 500      |
| 1000 x 1980                      | 500           |
| 1100 x 1480                      | 410, 500      |
| 1100 x 1580                      | 500           |

# CARRIER

## ARITCO 4000

### FULL HEIGHT WALL

The platform is in its basic execution delivered with a side wall (full height) including the destination panel. It comes with LED lightening and a mirror covering the panel over the destination panel as standard. The panel under the destination panel and the small roof over the mirror is painted in RAL 7042 (grey) as standard, but it can be painted in any RAL colour as an option.



### MIRROR

Mirror 800 x 970 mm is included as standard.



### FOOT BOX

As an option a special plate with a niche can be ordered for the bottom part of the platform. The niche adds a little bit of extra room at the bottom of the platform panel.

Size of niche: Depth 80 mm, height: 197 mm, length: 456 mm

The platform is in its basic execution delivered with a side wall (full height) including the destination panel.



A,B,C and D-side of paltform.

The platform is in its basic execution delivered with a side wall (half height) including the control panel.

#### HALF HEIGHT WALL

Used for lifts with an open shaft, half height doors or when cost must be kept down. Height 1100 mm. Panels around and under the control panel are painted in RAL 9016 (Traffic white) as standard, but it can be painted in any RAL color as an option

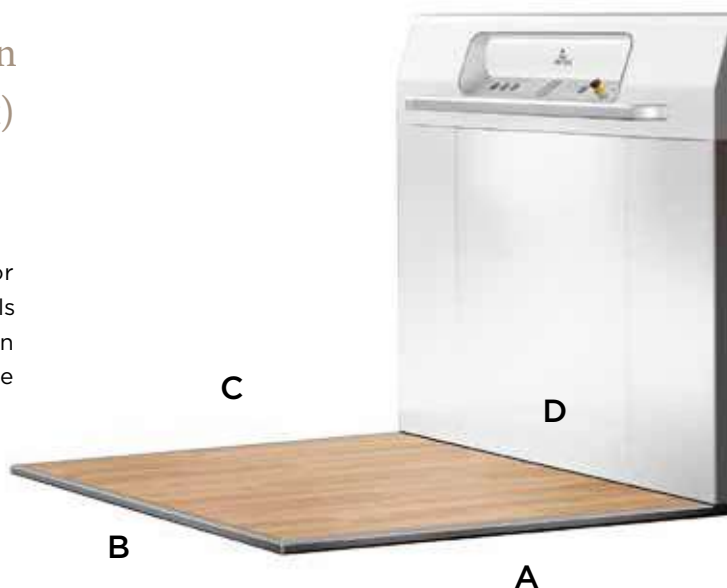

#### FULL HEIGHT WALL

To get a conventional lift feeling the Aritco Access lift can be delivered with a full height wall (2100 mm high) as an option. The full height wall has a big mirror that goes along the whole machine side. The mirror has an integrated LED light. Included as standard for full height wall. Panels around and under the control panel are painted in RAL 9016 (Traffic white) as standard, but it can be painted in any RAL color as an option. The full height wall is available for platform sizes with machine side 1040, 1280 and 1480 mm. When ordering a full height wall for platform 900 x 1040 mm, the electrical cabinet must be external.

#### FOLD DOWN SEAT

In solid birch and with chromed brackets. The seat has to be folded back manually after use. It can be ordered as an option.

Size: 320 x 400 mm.

Not available for 900x1040.



# CONTROL PANEL



## ARITCO 4000

The destination panel is always placed on the machine side(D-side) of the platform.

It contains the destination buttons, emergency stop, alarm button, autodialer (option), landing indicator (option), Aritco logo, max weight and number of persons allowed. All text and logos are screen printed to ensure good quality.

- Anodized aluminum - standard
- Stainless steel - option

## FACEPLATE PANEL

The faceplate panel in anodized aluminum (chemically polished) gives a soft finish to the platform. To prevent any trapping, a safety list is mounted behind the faceplate panel which cuts off the security circuit when pressed down.

## DESTINATION BUTTONS

Destination button with background lit frame, which indicates when the button is pressed down (green light). There are no signs on the destination buttons, instead it is possible to have your own text above the destination buttons on the destination panel.

Depending on the number of levels on the lift the destination buttons are either placed horizontally or vertically.

### For a 2-3 level lift:

- Maximum 10 characters. Destination buttons are placed horizontally.

### For a 4-6 level lift:

- Maximum 7 characters. Destination buttons are placed vertically.

All texts and logos are screen printed on the platform to ensure good quality and flexibility.



## ARITCO ACCESS LIFT,

## 2. ACCESSIBILITY VERSION (B)



The control panel is with 32 mm. buttons with text/numbers and braille. Following buttons are available: -2, -1, 0, 1, 2, 3, 4, 5, 6, 0A, 0B, 1A, 1B, 2A, 2B, 3A, 3B, BG, E, G, K, U, B

The touch plate of the buttons is in aluminum, black anodized (AlMg3 EV6). Text/number embossed. Height of text/number 15 mm. With Braille. 6 buttons/floors possible for all combinations, except for when having landing indicator and key lock on the control panel, then 5 buttons/floors are possible.

## 3. LARGE ACCESSIBILITY VERSION (C)



The control panel is with 50 mm. large buttons with text/numbers and braille. With the large buttons you have the possibility to provide enhanced accessibility. Often used in hospitals. Following buttons are available; -2, -1, 0, 1, 2, 3, 4, 5, 6, 0A, 0B, 1A, 1B, 2A, 2B, 3A, 3B, BG, E, G, K, U, B

The touch plate is in stainless steel in black. Text/number embossed. Height of text/number 30.3 mm. With Braille. 6 destination buttons/floors are possible when having a lift with only destination buttons. Due to space limitations on the control panel lifts with a landing indicator or key lock can have only 5 destination buttons/floors. For lifts with both landing indicator and key lock only 4 destination buttons/floors are possible.





↑x5 | 410 kg

Made in Sweden

## YOU CAN CHOOSE BETWEEN 3 DIFFERENT CONTROL PANELS.

1. HOME VERSION (A)
2. ACCESSIBILITY VERSION (B)
3. LARGE ACCESSIBILITY VERSION (C)

### LANDING INDICATOR (It can be ordered as an option.)

A digital display positioned at the control panel. It shows which floor the lift is on at the moment. The indicator can also be fitted with a voice announcer available in Danish, Dutch, English, Finnish, French, German, Norwegian, Polish, Russian and Swedish. Voice: Basement, Ground-floor, Floor 1-6.

The landing indicator can also show information from the system.

- Warning if the batteries are low.
- A bell when the alarm button has been pressed.
- Number of starts and total run time since installation or since last reset.
- A weight symbol will appear if the lift is overloaded.
- If connected to the buildings fire alarm a "Fire" symbol will be shown when alarm is activated.

### ALARM BUTTON

A standard alarm button is always delivered with the lift. When it is pressed a buzzer sounds. This is only a signal to the user that the button is pressed. The alarm button may be connected to an external alarm sounder or an autodialer. The alarm button is standard.

### EXTERNAL ALARM SOUNDER

(It can be ordered as an option.)

An external alarm sounder mounted outside the lift. It is connected to the alarm button and when the alarm button is pressed the external alarm sounder will give a loud signal outside the lift to attract attention in case of emergency.

### 1. HOME VERSION (A)

The control panel is with 32mm blank destination buttons. As identification for each floor an own text (max 10 signs) is written directly on the control panel. The touch plate of the buttons in neutral/flat and in matted stainless steel. 6 buttons/floor possible for all combinations, except for when having landing indicator and key lock on the control panel, then 5 buttons/floor are possible.

### EMERGENCY STOP BUTTON

A button in "mushroom" type for emergency situations. Light indicates if it is pressed down or not. It is always included as standard.

### HANDRAIL

A handrail is mandatory according to EN81-41 and delivered as a standard. Height of handrail is 875 mm. from the platform floor. The ends of the handrail are closed and turned to the platform. The handrail is made of aluminum with zinc corners and are painted in RAL 9016 (traffic white) as standard. When platform is ordered in another color than standard the handrail will be painted in grey, Anodic color Natura, that looks like aluminum. It is the same color as is used for the details around the control panel. Both the grey and white handrails will have a glossy surface to protect them from wear and tear and from getting dirty. In the handrail there is an integrated LED light, that gives light on the floor (50 LUX).

### GREEN RING - IDENTIFICATION FOR EXIT FLOOR

A green ring, indicating the exit floor can be selected on one of the destination buttons (max one per lift).



# DOORS

The doors are made of toughened galvanized steel and laminated and toughened glass which is 8 mm thick for the full height and half height glass door, and 17.5 mm thick for the Double-hinged glass door. The default door color is RAL 9016 (Traffic white), but any other RAL color can be selected as an option. The door frame and door blade can be painted in the same color or the frame in one color and the blade in another color. For the same lift all doors must be painted in the same colour.

The standard glass for Aritco Access Lift is clear glass (JTO). Optional is to have tinted glass (JT16). The standard for Aritco 4000 is clear glass (JTO). Optional is to have tinted glass (JT16), dark tinted (JT5) or frosted glass (JT23).



FULL HEIGHT GLASS DOOR

DOUBLE-HINGED GLASS DOOR

HALF HEIGHT DOOR WITH GLASS

| Door size measure (mm)      | Door type   |                      |             | Aritco 4000                 |                           | Aritco Access lift          |                           |
|-----------------------------|-------------|----------------------|-------------|-----------------------------|---------------------------|-----------------------------|---------------------------|
|                             | Full-height | Double-hinged        | Half-height | Available for A/C side (mm) | Available for B side (mm) | Available for A/C side (mm) | Available for B side (mm) |
| 800x1100                    | –           | –                    | AAL         | –                           | –                         | 900                         | 1040                      |
| 800x1101-1600 <sup>1)</sup> | –           | –                    | AAL         | –                           | –                         | 900                         | 1040                      |
| 900x1100                    | –           | –                    | AAL         | –                           | –                         | 1000/1100                   | 1280/1480                 |
| 800x1101-1600 <sup>1)</sup> | –           | –                    | AAL         | –                           | –                         | 1000/1100                   | 1280/1480                 |
| 800x1800                    | 4000/AAL    | –                    | –           | –                           | 805                       | 900                         | 1040                      |
| 800x1900                    | 4000/AAL    | –                    | –           | –                           | 805                       | 900                         | 1040                      |
| 800x2000                    | 4000/AAL    | Not Available B side | –           | –                           | 805                       | 900                         | 1040                      |
| 800x2100                    | AAL         | –                    | –           | –                           | –                         | 900                         | 1040                      |
| 900x1800                    | 4000/AAL    | –                    | –           | 1080                        | –                         | 1000/1100                   | 1280/1480/1580            |
| 900x1900                    | 4000/AAL    | –                    | –           | 1080                        | –                         | 1000/1100                   | 1280/1480/1580            |
| 900x2000                    | 4000/AAL    | Not Available B side | –           | 1080                        | –                         | 1000/1100                   | 1280/1480/1580            |
| 900x2100                    | AAL         | –                    | –           | –                           | –                         | 1000/1100                   | 1280/1480/1580            |
| 1000x2000                   | AAL         | –                    | –           | –                           | –                         | 1100                        | 1280/1480/1580            |
| 1000x2100                   | AAL         | –                    | –           | –                           | –                         | 1100                        | 1280/1480/1580            |

<sup>1)</sup> Custom height

## A HALF HEIGHT DOOR CAN BE USED IN THE FOLLOWING CASES:

- 1100 mm high half height door:  
When you have an open shaft and a top height of 1100 mm (even shaft).
- 1101-1600 mm high half height door:  
When you have a low travel height with a standard door on the bottom floor and a custom height half height door is needed to get an even shaft (see page 20 for details). When you have a higher travel height, but a standard door on second top floor and a custom height half door is needed to get an even shaft.
- It is not possible to have a lower half height door than the top height of the shaft - this means that you can't have a 1100 mm height door on a lift with shaft height of for example 1400 mm.
- Note that it is not possible to have two half height doors on the same lift.

| Door opening width (mm) | Door opening height (mm)        | Available for B-side (mm) | Available for A/C-side (mm) |
|-------------------------|---------------------------------|---------------------------|-----------------------------|
| 800                     | 1100<br>1101-1600 <sup>1)</sup> | 1040                      | 900                         |
| 900                     | 1100<br>1101-1600 <sup>1)</sup> | 1280/1480                 | 1000/1100 <sup>1)</sup>     |

<sup>1)</sup> Custom height

# HANDLE

## ARITCO 4000

Door handle in anodized aluminum with a straight shape as standard. Available in stainless steel as an option. Note that the door handle on a door on B-side of an Aritco 4000 could hit the building wall if the lift is installed very close to the wall on A or C side. This is since the door on the B-side does not have a door frame.



## ARITCO ACCESS LIFT

Door handles casted in zinc standard painted in grey, anodic Natura, that looks like luminum. For lifts ordered with door blades in standard color RAL 9016 (Traffic white) it is possible to order the door handles in the same color as an option. Both the grey and white door handles will have a glossy surface to protect them from wear and tear and from getting dirty.



Anodic Natura (Aluminum look) Traffic white (RAL 9016)

# FLOOR

## ARITCO 4000

Vinyl or rubber flooring. Choose between the following options. It is also possible to order the lift without a flooring, which enables the homeowner to choose and fit their own flooring. The maximum thickness of an externally selected floor is 3 mm.



Dark Grey, Vinyl

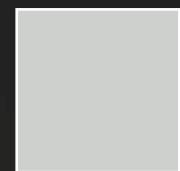

Light Grey, Vinyl

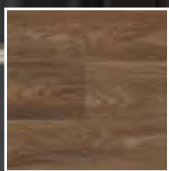

Aged Oak, Vinyl



Oiled Oak, Vinyl

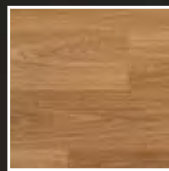

European Oak, Vinyl

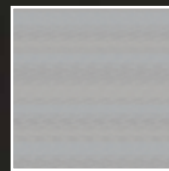

Bolon Flow Stream



Bolon Gradient

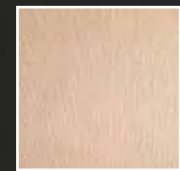

Bolon Sisal Plain Sand

## ARITCO ACCESS LIFT

It is also possible to order the lift without a flooring, which enables the homeowner to choose and fit their own flooring. The maximum thickness of an externally selected floor is 3 mm.

### Standard



Dark Grey Vinyl

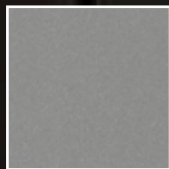

Light Grey, Vinyl

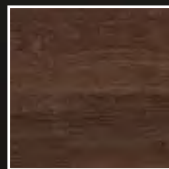

Aged Oak, Vinyl



Oiled Oak, Vinyl

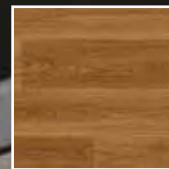

European Oak, Vinyl

### Option



Aluminum

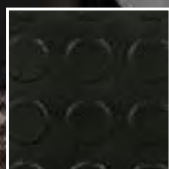

Checker Stud Black Rubber



Checker Stud Grey Rubber

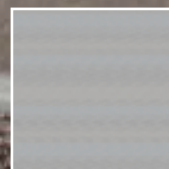

Bolon Flow Stream



Bolon Gradient



Bolon Sisal Plain Sand

# OPTIONS



## REMOTE CONTROL FOR OPERATION OF PLATFORM

A remote control is connected to the destination buttons on the platform. Instead of pressing the destination button on the platform, the button on the remote control can be pressed (hold to run). Remote control with 2 to 6 buttons, with numbers 2-6. One remote control per lift. One receiver per two floors. It can be ordered as an option.



## DOOR FACEPLATE

The door faceplate can be placed directly on the door frame or externally in an external call stationbox. The door faceplate is in standard painted in grey, anodic color Natura which has an aluminum look. The door faceplate can hold:

- Call button
- Key switch with Telemecanique / School locking
- Key switch prepared for ASSA or EUR / School locking
- Call button and key switch with Telemecanique / School locking
- Call button and key switch prepared for ASSA or EUR / School locking



## NUMERIC KEY LOCK

The numeric key lock can be used to add simple security without a key. The numeric code can be programmed from 4 digits to 10 digits and can be re-coded anytime. It can be ordered as options by replacing the call buttons or the destination buttons.

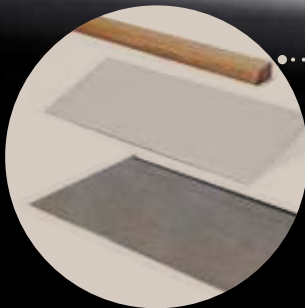

## THRESHOLD AND RAMP

For all lifts without a pit a door threshold in oak is delivered with the lift. A ramp can be delivered together with the door threshold for easier access to the lift. The ramp is made of galvanized steel, painted in RAL 9016 (Traffic white) as standard. If the shaft is painted in another RAL colour, the ramp will be painted in the same colour. It can be ordered as an option.

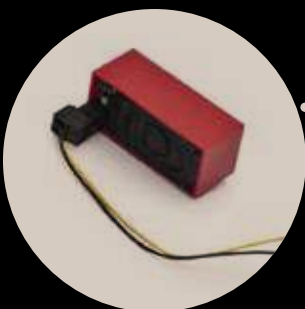

## ARRIVAL GONG

The arrival gong gives an audible signal (ding dong) when the platform arrives at each landing. It is placed in the door frame on each landing. It can be ordered as an option.



## PHONE

The telephone works as a standard telephone but is intended for emergency calls. The phone is mounted on the platform panel. Equipped with redial memory, mute button and a lamp indicator for on/off. It can be equipped with a GSM module. Aritco does not supply SIM card.

# OPTIONS

## LANDING INDICATOR ON DOOR

Digital display positioned at the door frame. It shows which floor the lift is on at the moment. The landing indicator can also show following system information:

- Warning if the lift batteries are low.
- A bell when the alarm button has been pressed.
- Number of starts and total run time since installation or since last reset.
- A weight symbol will appear if the lift is overloaded.
- If connected to the buildings fire alarm a "Fire" symbol will be shown when alarm is activated.



## EXTERNAL SERVICE PANEL

A service panel is always placed in the electrical cabinet. It is used to run tests etc., and for emergency running the lift. An external service panel is available for mounting outside the lift as an option. In this case a wire connects it with the service panel in the electrical cabinet. For all platform sizes for Aritco 4000 the electrical cabinet and the standard service panel is mounted in the top part of the shaft and can't be reached from outside. Therefore it is connected to an external service panel (wall mount) which is mounted in a faceplate box. The external service panel must be activated with a 3 edge key before it can be used. Size: 95 x 185 mm



## POWER SUPPLY

For Aritco Access lift you have the following options:

**3-phase 400V 50 Hz/5.2 A/16 A slow**

- Standard for all lifts • For 250, 410 and 500 kg

**1-phase 230V 50 Hz/9 A/16 A slow**

- Option when building don't support 400V 3-phase

- Frequency converter with built in soft start and stop • For 250 and 410 kg

**3-phase 230V 50 Hz/9 A/16 A slow**

- Option • Note that this is rarely used except for example in Norway

- For 250, 410 and 500 kg

For Aritco 4000 the following is valid:

**1-phase 230 V/50Hz/6.6A/16A slow**

- Frequency converter with built in soft start and stop • For 250 kg

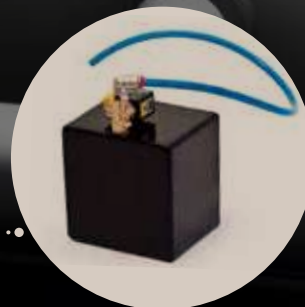

## AUTOMATIC LUBRICATION

Oils the driving screw at regulated time intervals even if the lift is not in use. The lubrication frequency is adjustable. Standard for Aritco 4000. Standard for lifts with a travel height of over 8000 mm. Recommended for lifts that are seldom used or that are not used regularly to travel from ground to top floor.



## BATTERY OPERATED EMERGENCY LOWERING

All Aritco lifts have battery operated emergency lowering as standard. You can lower yourself from inside the lift and get out by yourself when there is a power failure. Possible to run the lift to nearest level from the platform (possible to go down) - Executed when pressing a destination button. Can also be run externally from the call button (hold to run) or service box. Mandatory if the position of the electrical cabinet is on an alternate landing than the top floor. Battery operated emergency lowering is mandatory for platform size 900x1040 mm since the electrical cabinet is mounted behind the platform panel and in top of the shaft and therefore can't be reached from outside.



## FOLD DOWN SEAT FOR ARITCO ACCESS LIFT

In solid birch and with chromed brackets. The seat has to be folded back manually after use. Can be ordered as an option  
Size: 320 x 400 mm



## FOOT BOX FOR ARITCO 4000

As an option a special plate with a niche can be ordered for the bottom part of the platform. The niche adds a little bit of extra room at the bottom of the platform panel.

Size: Depth 80 mm, height: 197 mm, length: 456 mm.



# DOOR MACHINERY

The landing doors are always delivered with either a door opener or a door closer.

| Door type                      | Internal door closer | External door closer | External door opener | External door opener FAAC |
|--------------------------------|----------------------|----------------------|----------------------|---------------------------|
| Large glass door Standard      | ✓                    | ✓                    | ✓                    | ✓                         |
| Half height glass door         | ✓                    | -                    | ✓                    | -                         |
| EI60 - fire & smoke proof door | ✓                    | -                    | ✓                    | ✓                         |
| Outdoor lifts                  | ✓                    | ✓                    | ✓                    | ✓                         |



## INTERNAL DOOR CLOSER

Closes the door automatically after a preset time. It is built into the door frame and is invisible from the outside. Includes function to keep door open until the user manually closes the door. Standard for all doors except large glass doors with 50 mm frametop.

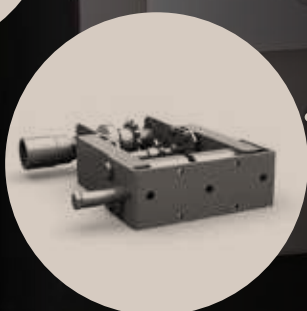

## INTERNAL DOOR OPENER

Opens and closes the door automatically. It is built into the door frame and can't be seen from the outside. It can be ordered as option. Standard for double hinged glass doors.



## EXTERNAL DOOR CLOSER

Closes the door automatically. It can be ordered as an option.



## HOLD OPEN ARM

Keeps the door open until the user manually closes the door. Can be combined with external door closer only. It can be ordered as an option.



## EXTERNAL DOOR OPENER

Opens and closes the door automatically after a preset time. It can be ordered as option. Cover and sides painted in RAL 9016 (Traffic white) as standard. If the door blade is painted in another color, the cover will be painted in the same color. The sides will still be in RAL 9016 (Traffic white).



## EXTERNAL DOOR OPENER FAAC

Opens and closes the door automatically after a preset time. Suitable for tougher public & commercial environments. For both indoor and outdoor installations. The opener is installed on the door frame which makes it suitable for installations where space is limited and when lift door opens up close to a wall. Smart logic makes it possible to program the speed and force, depending on door type. If an obstacle is detected, the door re-opens immediately. Then it closes, checking, at reduced speed, that the obstacle is no longer present. Cover in aluminum and sides in grey plastic. It can be ordered as option.

# LIFT WALL

## MAST

Aritco Access Lift is always delivered in parts.

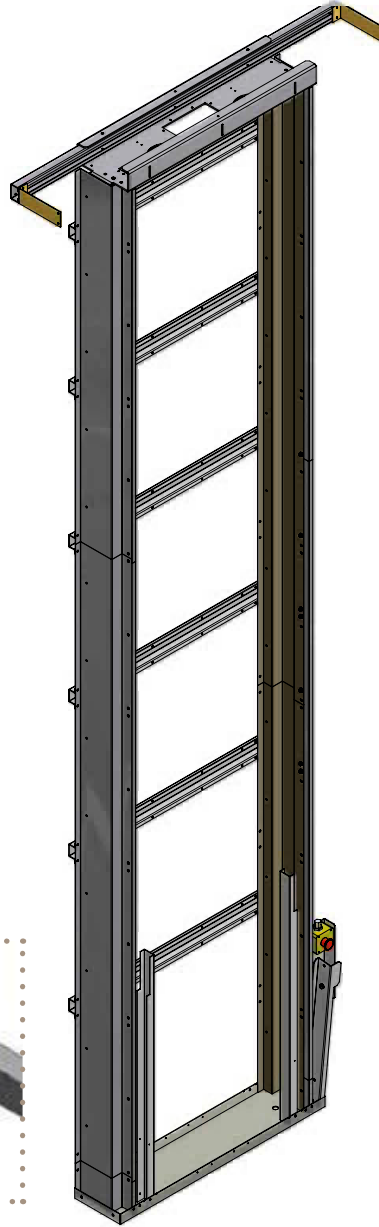

## SHAFT SUPPORT BRACKET / L-BRACKET

Installed to stabilize the shaft when it is not mounted against a wall. One shaft support bracket shall be used per floor, except the bottom floor. The shaft support bracket/L-bracket is fixed to the lift on the machine side and in the building on A/Cside (under door). Not possible to fix on B-side. The shaft support bracket/L-bracket is painted in RAL 9016 (Traffic white) as standard. If the shaft is painted in another color the shaft support bracket is painted in the same color. The shaft support bracket / L-bracket is available for platform sizes 1040, 1280, 1480, 1580 and 1980 mm.

## INNER CEILING

For a closed shaft you can add an inner ceiling as an option. The inner ceiling is painted in RAL 9016 (Traffic white) as standard, but it can be painted in different color according to the shaft. It comes with built-in LED light which complies with LUX regulation.

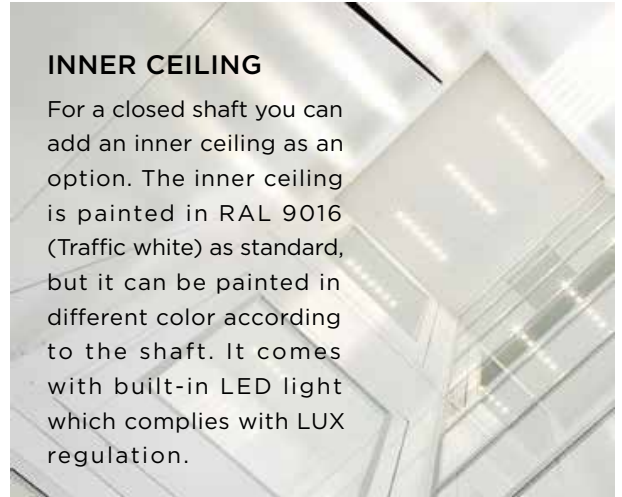

## ELECTRICAL CABINET

The standard position of the electrical cabinet is in the shaft, at the upper floor where the landing door is located. If the standard position of the electrical cabinet proves difficult, Aritco offer the option to move it to another landing or to place it externally in a lockable casing. For platform size 900x1040 mm the electrical cabinet is mounted behind the platform panel in the top of the shaft. When ordering a full height wall for platform 900x1040 mm, the electrical cabinet must be external. Size of standard electrical cabinet (placed in shaft): 180 x 880 mm. Size of external electrical cabinet (placed in an external box): Height 500 mm, depth: 160 mm, width: 400 mm.



## EXTERNAL SERVICE PANEL

A service panel is always placed in the electrical cabinet. It is used to run tests etc., and for emergency running the lift. An external service panel is available for mounting outside the lift as an option. In this case a wire connects it with the service panel in the electrical cabinet. For platform size 900 x 1040 the electrical cabinet and the standard service panel is mounted in the top part of the shaft and can't be reached from outside. Therefore it is connected to an external service panel (wall mount) which is mounted in a faceplate box. The external service panel must be activated with a 3 edge key before it can be used. Size: 95 x 185 mm



## ARITCO 4000

The lift is always delivered with a self supporting shaft. The top height of the shaft (distance from top floor to top of shaft) is always 2300 mm. If the lift isn't installed against a wall, machine side cladding can be added on the outside of the lift on the machine side. For all sides except for machine side you can choose to have shaft panels in steel or glass.

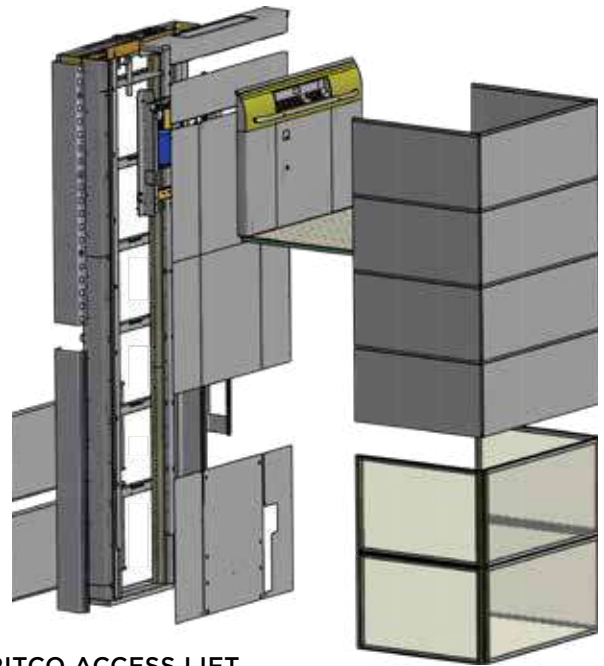

## ARITCO ACCESS LIFT

The lift is always delivered with a self supporting shaft. The lift always comes with cladding panels on the inside of the shaft on the machine side. If the lift is not installed against a wall, machine side cladding can be added on the outside of the lift to cover the machine side. For all sides except for the machine side you can choose to have shaft panels in steel or glass. The top height of the shaft for Aritco Access lift is not fixed. When having a standard door on the top floor, the minimum top height depends on the door opening height and the frame height. For a door opening height of 2000 mm. the standard frame height is 2240 mm., which is the lowest top height. Higher top height can be ordered. Maximum top height is 4000 mm.

## SCREW & DRIVE SYSTEM



### Screw and Drive nut

Roll pressed steel – guarantees the quality  
 The nut is turning – not the screw  
 Safety: 8 times the maximum load.  
 Self locking concept.  
 No additional motor brake is necessary.  
 Vibration reduction due to a patented nut design.  
 If maintained correctly, no oil waste due to our lubrication system 40 mm screw

## ALL OF ARITCO LIFTS CAN BE PAINTED IN ANY RAL COLOUR FROM THE CHART K7

Following choices are available:  
 Whole lift painted in standard colour RAL 9016 (Traffic white):

- Whole lift painted in RAL 9016 except for the platform panels which are painted in RAL 7042 (Grey).
- Whole lift painted in other RAL colour from the chart K7
- Whole lift painted in optional RAL colour (Incl. shaft, doors and platform panels.)



### Lift partially painted in different RAL colours:

- Shaft in one RAL colour (Incl. shaft panels, corner profiles, Architraves, etc.)
- All door blades in one RAL colour.
- All door frames in one RAL colour (Also includes the door faceplate.)
- Platform panels in one RAL colour.
- One of the above choices or a combination of them.

## NEW RAL COLOUR (JOTUN FACADE SAHARA)

|                           |                          |                            |                        |                             |                       |
|---------------------------|--------------------------|----------------------------|------------------------|-----------------------------|-----------------------|
|                           |                          |                            |                        |                             |                       |
| TRAFFIC WHITE<br>RAL 9016 | GREY WHITE<br>RAL 9002   | WHITE ALUMINUM<br>RAL 9006 | TELEGREY 1<br>RAL 7045 | ANTHRACITE GREY<br>RAL 7016 | JET BLACK<br>RAL 9005 |
|                           |                          |                            |                        |                             |                       |
| PURE WHITE<br>RAL 9010    | OYSTER WHITE<br>RAL 1013 | LIGHT IVORY<br>RAL 1015    | MOSS GREEN<br>RAL 6005 | BROWN RED<br>RAL 3011       |                       |



## WHAT KIND OF WHEELCHAIR CAN BE FITTED IN THE LIFT?

Aritco Access lift follows the requirements stated for lifts regarding the possibility to fit a wheelchair with or without attendant. Depending on the size of the platform / cabin you can fit either a wheelchair or a wheelchair with an attendant :

### Type A and B wheelchairs are defined in :

EN 12183 Manual wheelchairs - requirements and test methods

EN 12184 Electrically powered wheelchairs, scooters and their charges - Requirements and test methods

| Dimensions of wheelchair | Class A | Class B |
|--------------------------|---------|---------|
| Total length             | 1200    | 1400    |
| Total width              | 700     | 700     |

| Aritco Access lift |   |
|--------------------|---|
| Platform size      |   |
| 900x1040           | -   |
| 900x1280           | Lone user, or type A wheelchair                             |
| 900x1480           | Type A and B wheelchair with attendant                      |
| 1000x1280          | Lone user, or type A wheelchair                             |
| 1000x1480          | Type A and B wheelchair with attendant                      |
| 1000x1980          | Type A and B wheelchair with attendant                      |
| 1100x1480          | Type A and B wheelchair with attendant and adjacent entries |
| 1100x1580          | Type A and B wheelchair with attendant and adjacent entries |

## WHAT ARE THE REACTION FORCES ON THE BUILDING AND FORCE ON FIXINGS TO SUPPORT FRAME TO WALL?

Details regarding the forces are available in the installation manual for Aritco Access lift

### REACTION FORCES FROM THE LIFT TO THE BUILDING:

- Maximum force as a function of the lift's travel. The force is distributed to the floor through the mast bottom with the area "A" and to the shaft bottom with the area "B".

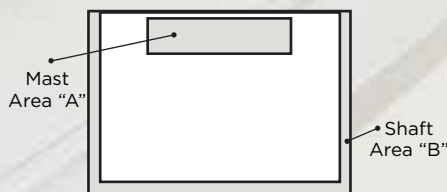

| Travel height (m) | Aritco Access lift |                             |                            | Aritco 4000 |
|-------------------|--------------------|-----------------------------|----------------------------|-------------|
|                   | Area "A" F(kN)     | Area "B" Shaft panels F(kN) | Area "B" Glass Shaft F(kN) | F(kN)       |
| 1                 | 7.8                | 2.55                        | 3.30                       | 3.9         |
| 2                 | 8.5                | 3.40                        | 4.40                       | 4.1         |
| 3                 | 9.2                | 4.25                        | 5.50                       | 4.2         |
| 4                 | 9.9                | 5.10                        | 6.60                       | 4.3         |
| 5                 | 10.7               | 5.95                        | 7.70                       | 4.4         |
| 6                 | 11.5               | 6.80                        | 8.80                       | 4.5         |
| 7                 | 12.0               | 7.65                        | 9.90                       | 4.7         |
| 8                 | 12.8               | 8.50                        | 11.00                      | 4.8         |
| 9                 | 13.4               | 9.35                        | 12.10                      | 5.0         |
| 10                | 14.2               | 10.20                       | 13.20                      | 5.2         |
| 11                | 14.9               | 11.05                       | 14.30                      | 5.3         |
| 12                | 15.6               | 11.90                       | 15.40                      | 5.5         |

### FORCE ON FIXING TO SUPPORT FRAME (MAST) TO WALL:

- c-c = distance (height) from the floor to the highest fixing into the wall.
- The maximum distance between two fixings or lower floor and the lowest fixing is 4.0 m. For outdoor lifts maximum distance is 3.0 m.
- The minimum distance between lower floor and the highest fixing is 2.0 m.
- c-t = distance from the top of the mast to the highest fixing into the wall.
- The maximum distance between the top of the mast and highest fixing is 1.2 m.

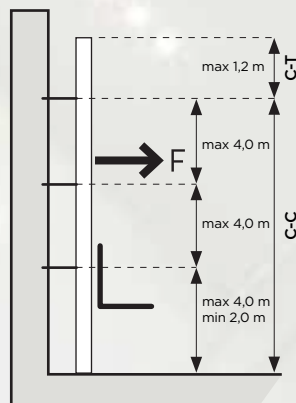

| c - c (m) | Aritco Access lift |                   | Aritco 4000       |
|-----------|--------------------|-------------------|-------------------|
|           | F(kN) 410 kg load  | F(kN) 500 kg load | F(kN) 255 kg load |
| 2         | 1.5                | 2.2               | 0.84              |
| 3         | 1.0                | 1.5               | 0.56              |
| 4         | 0.8                | 1.1               | 0.42              |
| 5         | 0.6                | 0.9               | 0.34              |
| 6         | 0.5                | 0.7               | 0.28              |
| 7         | 0.4                | 0.6               | 0.24              |
| 8         | 0.5                | 0.5               | 0.21              |
| 9         | 0.3                | 0.5               | 0.19              |
| 10        | 0.3                | 0.4               | 0.17              |

# OUTDOOR VERSION

Aritco Access Lift Outdoor is designed for outdoor use. All outdoor lifts are delivered with guide rails in corrosion class C5.

The outdoor version consists of different options that enable an outdoor installation. Depending on the installation environment different options must be added and the installation conditions that are specified must be followed.

## VENTILATION FANS

Ventilation fans mounted in top of the shaft. Two axial fans 230 V, 12 W. The fans are connected to an external power socket, 230 V. The fans are mandatory for outdoor lifts.



## ROOF

Roof for outdoor version. If the lift is not installed in an external shaft, an outer roof must be used. One roof corner is left open for water outlet. The roof is made of galvanized steel and painted in RAL 9016 (Traffic white) as standard. An inner ceiling with light must be ordered for outdoor lifts when ordering a roof.

## DOOR CANOPY

A sloping roof placed above the landing doors to protect them from rain and snow etc. The door canopy is made of galvanized steel and painted in RAL 9016 (Traffic white) as standard. Width: 1160 mm, Slope angle: 23°

# DIMENSION PLATFORM

## ARITCO 4000

### Platform 880 x 805

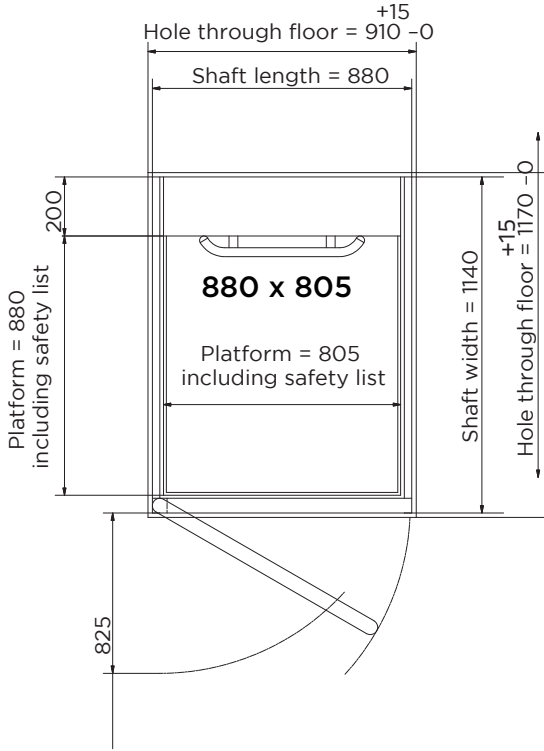

### Platform 580 x 805

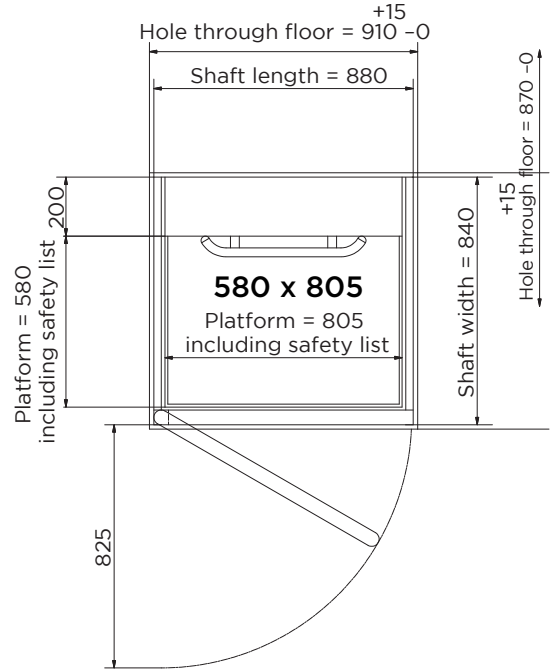

### Platform 1080 x 805

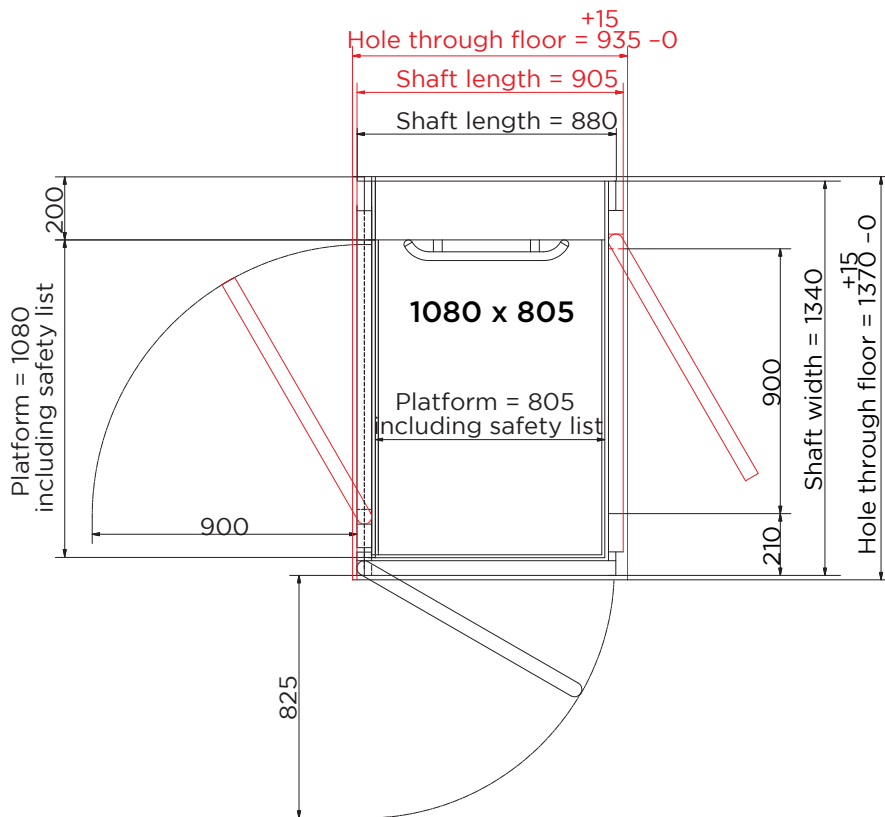

# DIMENSION PLATFORM

## ARITCO ACCESS LIFT

**Platform 900 x 1040**

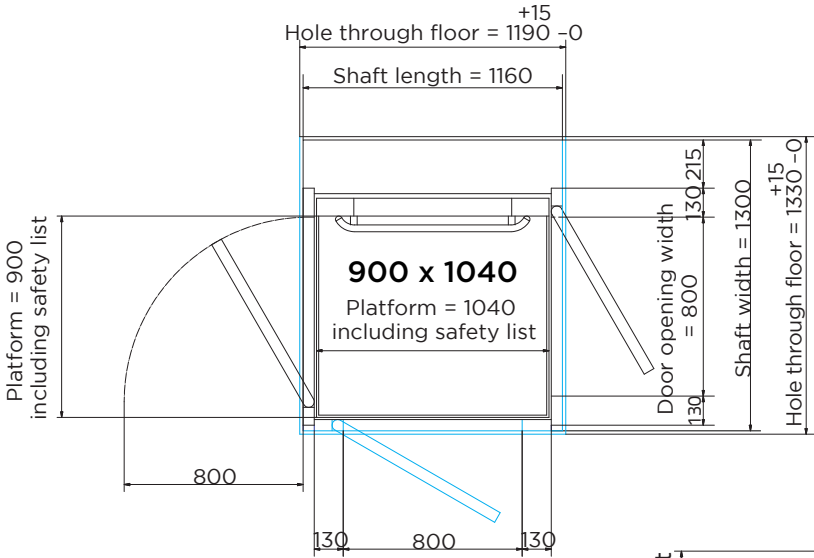

**Platform 900 x 1280**

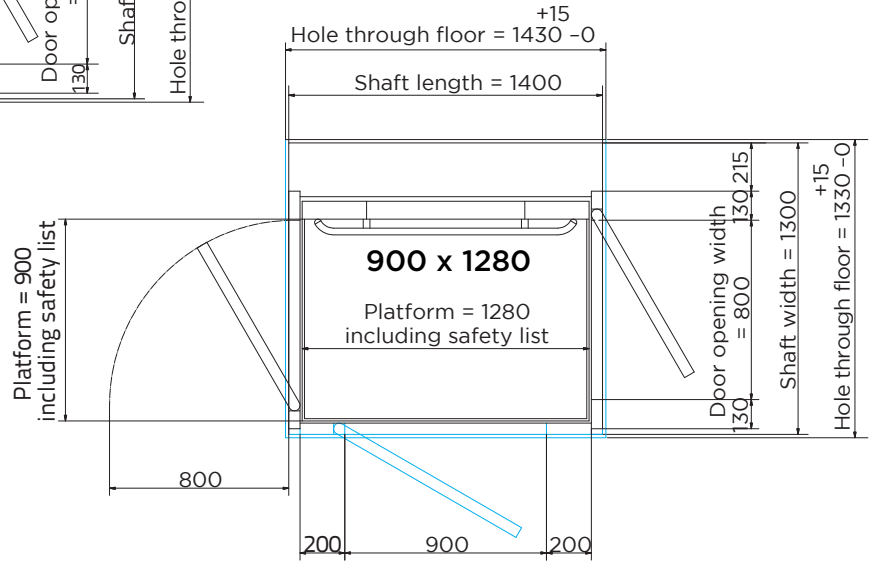

**Platform 900 x 1480**

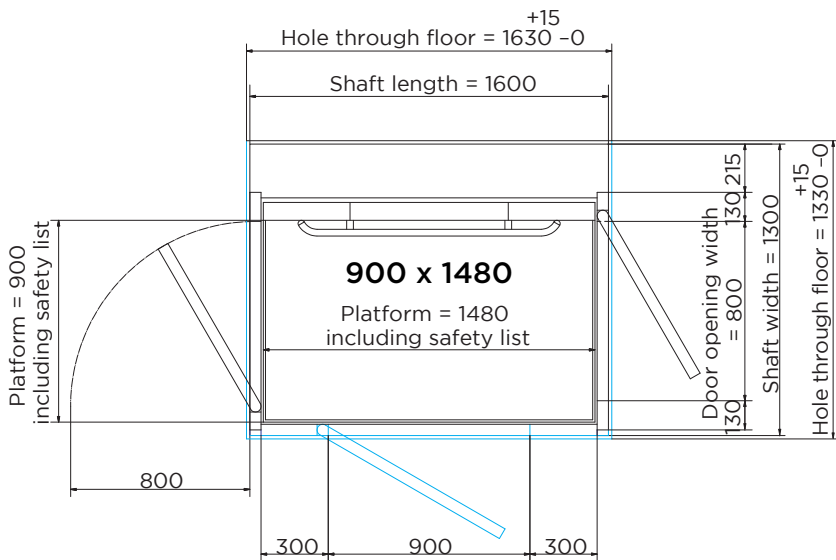

**Platform 1000 x 1280**

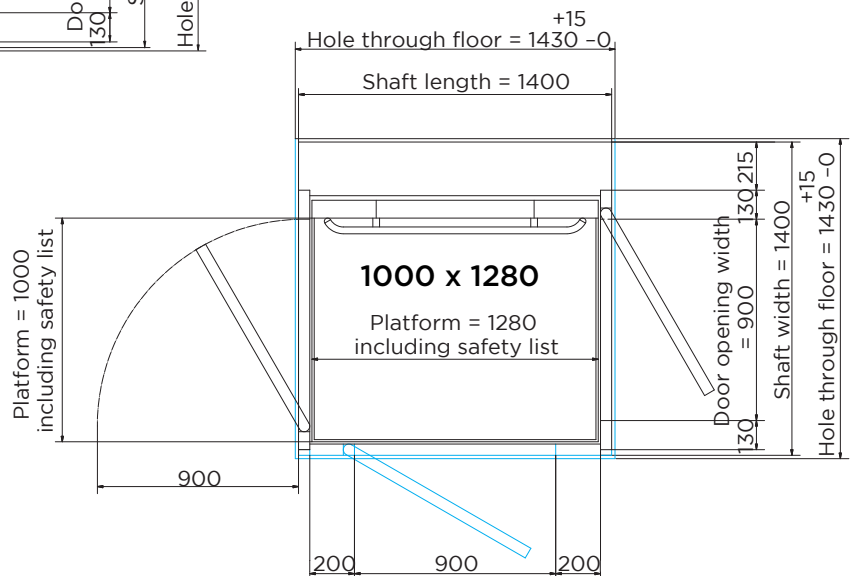

# DIMENSION PLATFORM

**Platform 1000 x 1480**

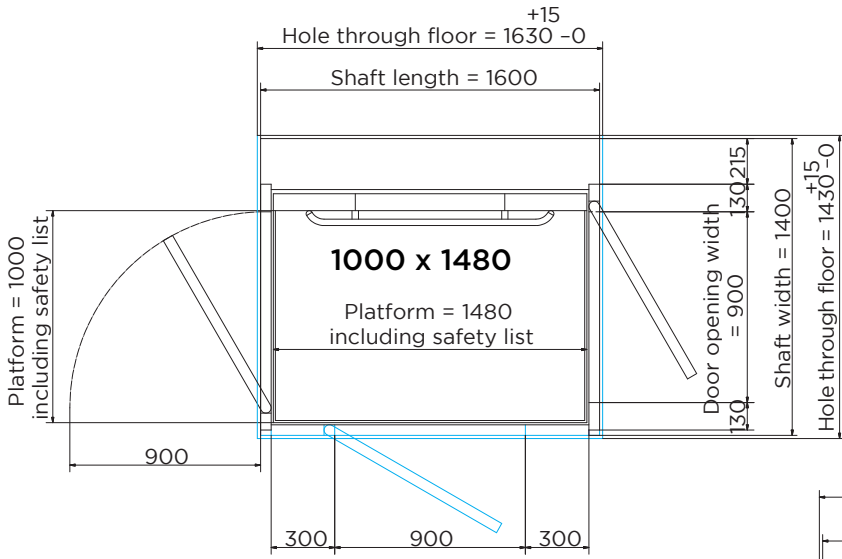

**Platform 1000 x 1980**

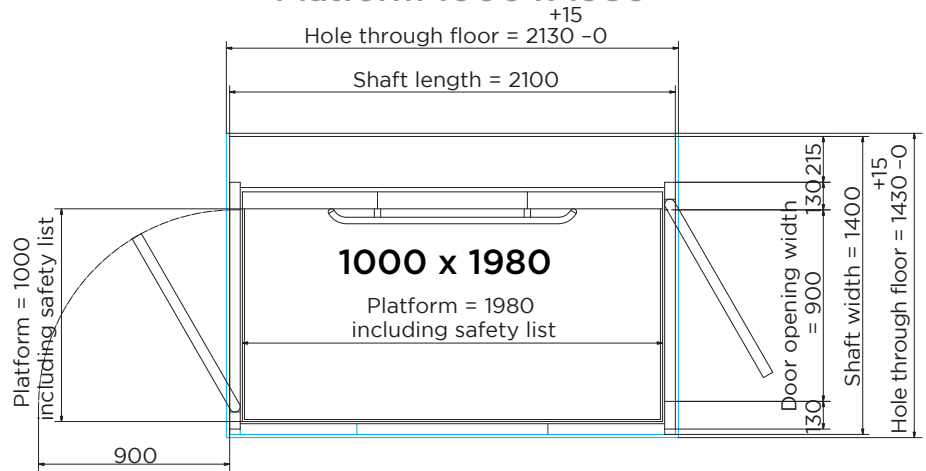

**Platform 1100 x 1480**

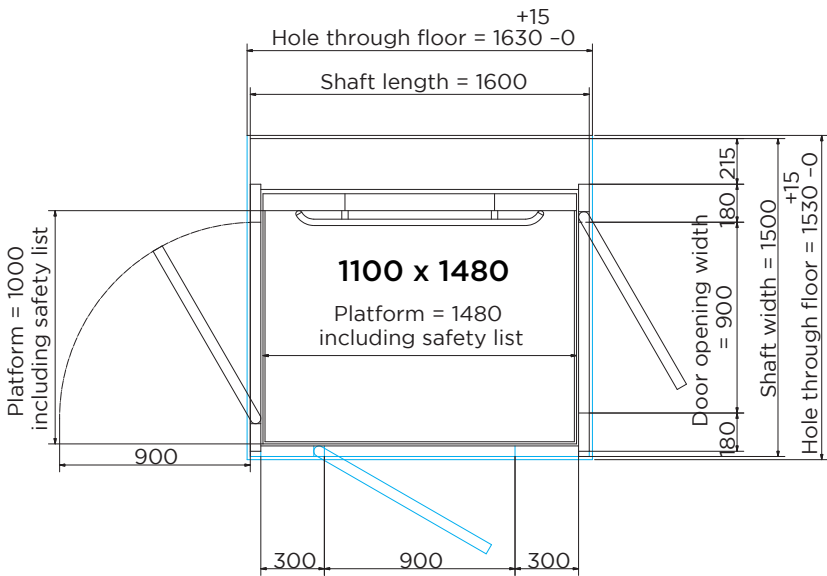

**Platform 1100 x 1580**

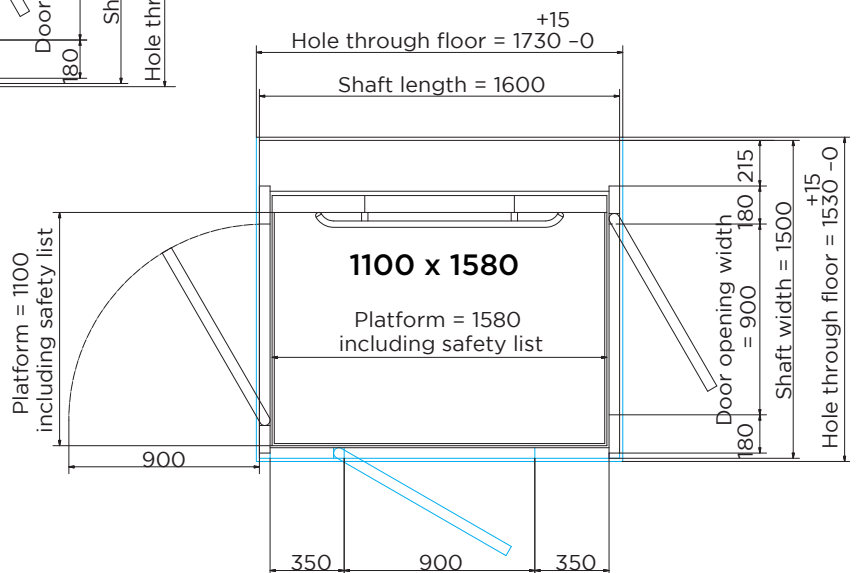

# REFERENCE PICTURES OUTDOOR



# REFERNCE PICTURES INDOOR





Up to 13 m travel height with maximum of 6 stops

Most efficient space utilization

Choices of panoramic glass or solid shaft panel on three sides

Compliance with European safety standards and regulations

Patented screw drive system to ensure owner's safety and comfort.

Simple, compact and easy to install (less than 1 week) anywhere - indoor/outdoor

Require little or no modification to existing building

Up to 11 available platform sizes

Only 21.5cm thick mechanical shaft

Only 1500 watts to operate the lift, 10 watts when standby

Built-in back up electrical and mechanical lowering systems in case of power failure

No separate machine room or special built structure needed

Built-in 5 emergency stops system to ensure extra safety.

No extra head room or pit required



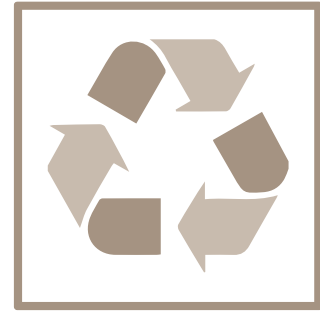
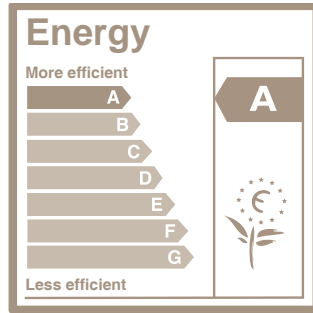
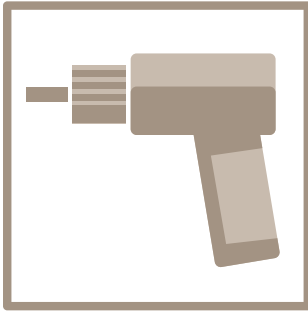

### **EASY INSTALLATION**

Means that the lift is both easy and fast to install. A normal installation takes only two days.

### **MINIMUM BUILDERS WORK AND SMALL FOOTPRINT**

The lift can be installed without a pit, with a ramp (or with a 50 mm pit without ramp). All parts are included in the shaft - no extra machine room or head room needed.

### **LOW ENERGY CONSUMPTION**

Minimum standby power consumption 15 W - not more than a computer or a TV. Energy class A as per VDI 4707.

### **ENVIRONMENTAL PRODUCT DECLARATION**

Aritco is the first lift manufacturer with an Environmental Product Declaration. More than 95% of the parts are recyclable.

### **LOW OPERATION AND MAINTENANCE COST**

Lowest on the market.

### **NO HYDRAULICS, WHICH MEAN NO LEAKAGE OR SMELL**

No additional space needed for hydraulic unit.

### **ROBUST SHAFT**

25 mm shaft panels. Robust and resistant to damage. Good noise and acoustical isolation.

### **SMARTSAFETY SYSTEM**

Lift is designed with reliability and safety in focus; to meet all kinds of situations that can occur in a home, as well as to prevent accidents. All these safety features are included in the Smart-Safety System. The lift contributes and helps you to create a home that is safe and accessible for anyone ;

#### **• Screw and nut drive system:**

The self-sustaining concept, i.e. the friction between screw and nut will prevent the lift from falling down. No additional brake system is needed.

#### **• Power failure operation:**

If there is a power failure, you can always get out of the lift by yourself with battery operated emergency lowering. Use the platform buttons and the lift will take you to the closest lower floor and you can open the door and get out by yourself.

#### **• Emergency calls and emergency operation:**

If you are trapped in the lift you can make emergency calls from a phone. It is also possible to lower the lift and get out of the lift

#### **• Safety edges:**

Safety edges around the platform and the platform wall will prevent something to get trapped between the moving platform and the shaft/walls.

#### **• Locking of lift:**

Key switch lock on the platform or the call station that prohibits unauthorized use of the lift.





ARITCO is a world-leading manufacturer of platform lifts and home lifts. More than 35,000 lifts are installed in more than 40 countries worldwide. In Thailand, ARITCO Showroom is situated on Rama III Road, showcasing different models of home lifts to create comprehensive solutions to best match all customers' demands in relaxing vibes. It also functions as the data center to house engineering team for real-time after sales services. Open daily from 9:00- 6:00 pm



**ARITCO (THAILAND) CO., LTD.**

**467/2 Rama 3 Road,  
Bang Khlo, Bang Kho Leam,  
Bangkok 10120, Thailand**

**T: 088 333 2020 • 088 333 5050 • 088 333 9090**

**F: 02 683 8877**

**E: [sales@aritco.co.th](mailto:sales@aritco.co.th)**

**W: [www.aritco.co.th](http://www.aritco.co.th)**

**FB: [Facebook.com/aritcothailand](https://www.facebook.com/aritcothailand)**

**Line official: [@aritcohomerlifts](https://www.line.me/@aritcohomerlifts)**



Website



Map



Line official